

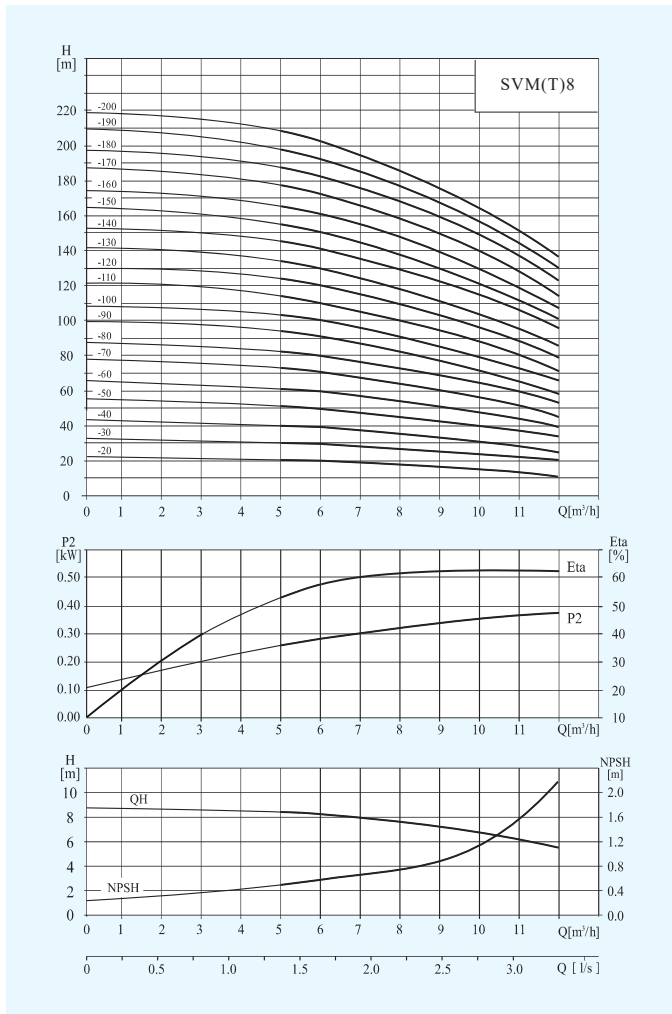

# Stainless Steel Vertical Multistage Pump — 60Hz — SVM(T)8

## Performance Curves



## Model Description

SVM(T)1/2/3/4/5/8/10/12/15/16/20

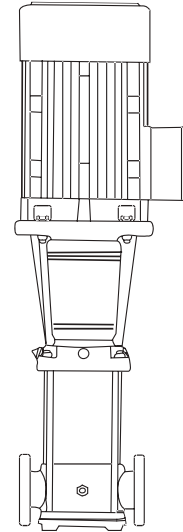

**SVM/SVMT**

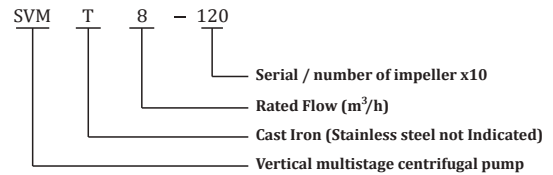

## Size and weight

Model	Size (mm)					Weight (kg)
	B1	B2	B1+B2	D1	D2	
SVM8-10	310	250	560	170	142	32
SVM8-20	357	290	647	190	155	38
SVM8-30	387	290	677	190	155	41
SVM8-40	427	315	742	197	165	49
SVM8-50	457	315	772	197	165	50
SVM8-60	487	335	822	230	188	58
SVM8-80	567	430	997	260	208	71
SVM8-100	627	430	1057	260	208	80
SVM8-120	687	430	1117	260	208	82
SVM8-140	835	490	1325	330	255	153

# Stainless Steel Vertical Multistage Pump — 60Hz — SVM(T)8

## Structure chart: SVM(T)8/10/12/15/16/20

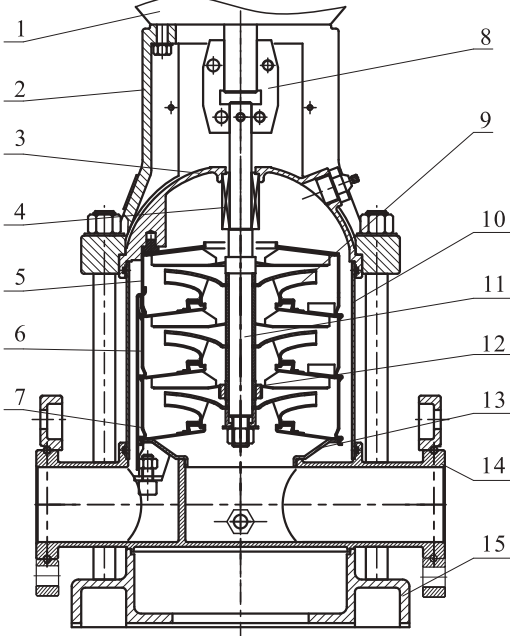

SVM

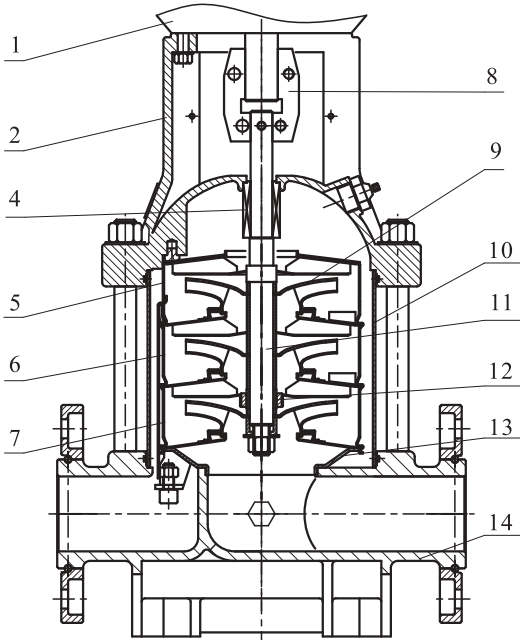

SVMT

## Material:SVM(T)8/10/12/15/16/20

No	Description	Material	AISI/ASTM
1	Motor	Assembling unit	
2	Support	Cast Iron/ Ductile iron	ASTM25B ASTM70-50-05
4	Mechanical seal	Assembling unit	
5	Outlet guide vane	Stainless Steel	AISI304
6	Guide vane	Stainless Steel	AISI304
7	Support guide vane	Stainless Steel	AISI304
8	Coupling	Ductile iron	ASTM70-50-05
9	Impeller	Stainless Steel	AISI304
10	Shell	Stainless Steel	AISI304
11	Pump Shaft	Stainless Steel	AISI304 AISI316L
12	Bearing	Tungsten Carbide	
13	Inlet guide vane	Stainless Steel	AISI304
<b>SVM</b>			
3	seal seat	Stainless Steel	AISI304
14	Inlet &outlet seat	Stainless Steel	AISI304
15	Seat	Cast Iron	ASTM25B
<b>SVMT</b>			
14	Inlet &outlet seat	Cast Iron	ASTM25B