

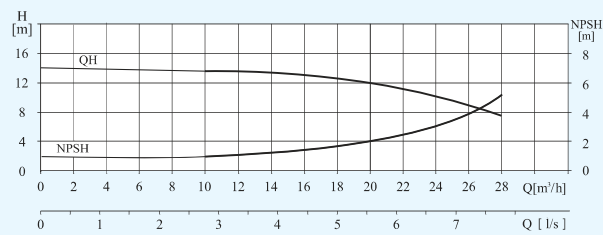

# Stainless Steel Vertical Multistage Pump — 60Hz — SVM(T)20

## Performance Curves

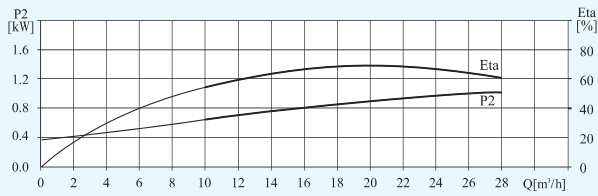
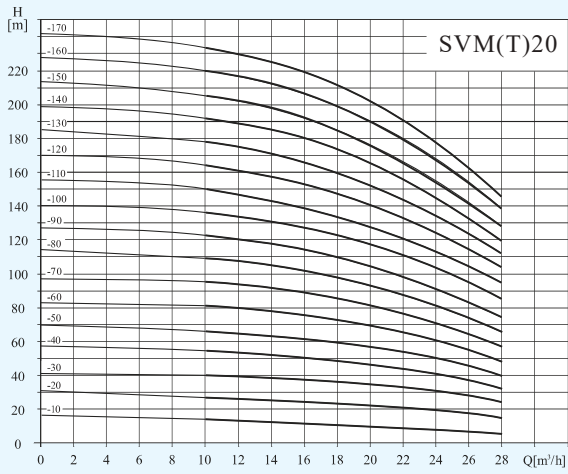

## Model Description

SVM(T)1/2/3/4/5/8/10/12/15/16/20

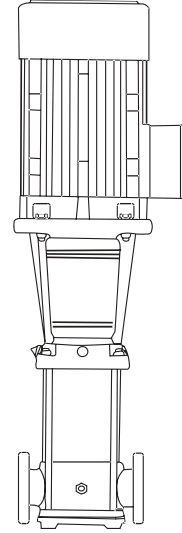

**SVM/SVMT**

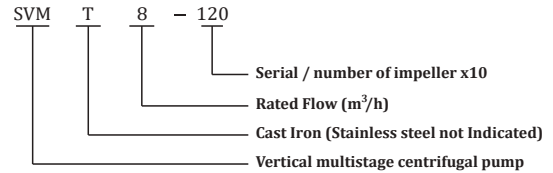

## Size and weight

Model	Size (mm)					Weight (kg)
	B1	B2	B1+B2	D1	D2	
SVM20-10	352	290	642	190	155	41
SVM20-20	407	335	742	230	188	56
SVM20-30	472	430	902	260	208	69
SVM20-40	517	430	947	260	208	79
SVM20-50	650	490	1140	330	255	148
SVM20-60	695	490	1185	330	255	150
SVM20-70	740	490	1230	330	255	162
SVM20-80	785	490	1275	330	255	163
SVM20-100	875	550	1425	330	255	187

# Stainless Steel Vertical Multistage Pump — 60Hz — SVM(T)20 —

## Structure chart: SVM(T)8/10/12/15/16/20

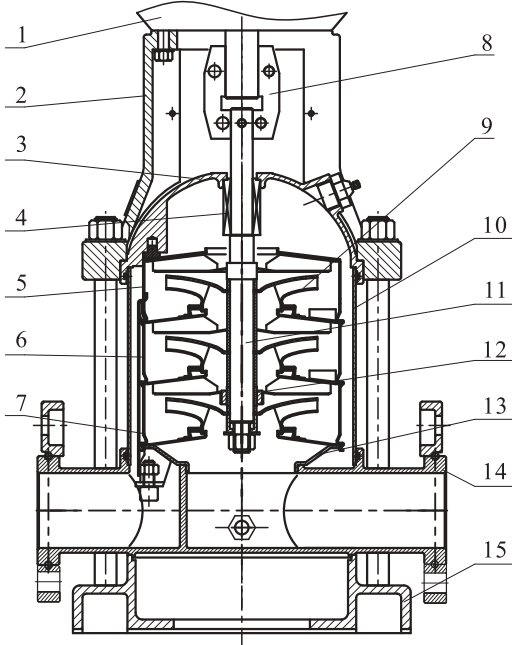

SVM

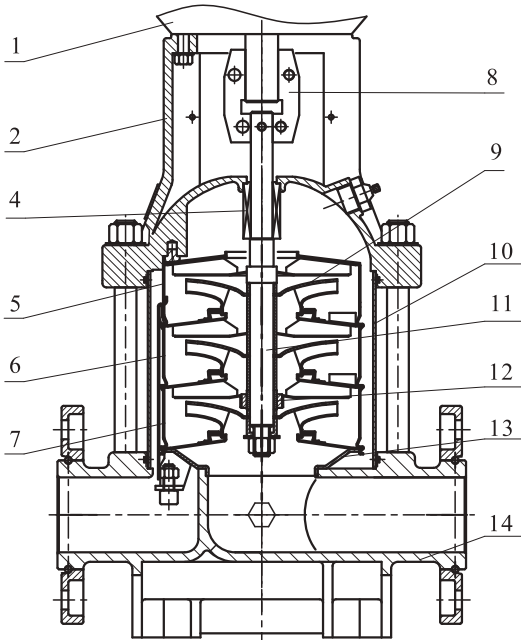

SVMT

## Material:SVM(T)8/10/12/15/16/20

No	Description	Material	AISI/ASTM
1	Motor	Assembling unit	
2	Support	Cast Iron/ Ductile iron	ASTM25B ASTM70-50-05
4	Mechanical seal	Assembling unit	
5	Outlet guide vane	Stainless Steel	AISI304
6	Guide vane	Stainless Steel	AISI304
7	Support guide vane	Stainless Steel	AISI304
8	Coupling	Ductile iron	ASTM70-50-05
9	Impeller	Stainless Steel	AISI304
10	Shell	Stainless Steel	AISI304
11	Pump Shaft	Stainless Steel	AISI304 AISI316L
12	Bearing	Tungsten Carbide	
13	Inlet guide vane	Stainless Steel	AISI304
<b>SVM</b>			
3	seal seat	Stainless Steel	AISI304
14	Inlet &outlet seat	Stainless Steel	AISI304
15	Seat	Cast Iron	ASTM25B
<b>SVMT</b>			
14	Inlet &outlet seat	Cast Iron	ASTM25B