

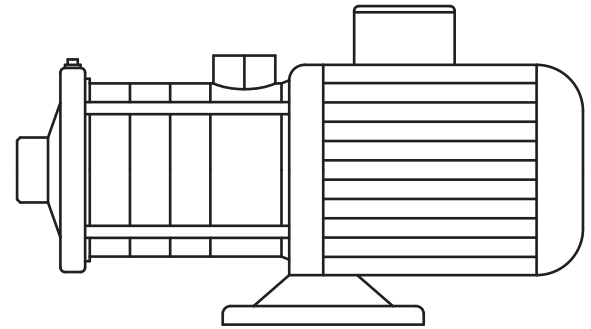

# Stainless Steel Horizontal Multistage Pump — 60Hz — SHM(T)4

## Performance Curves

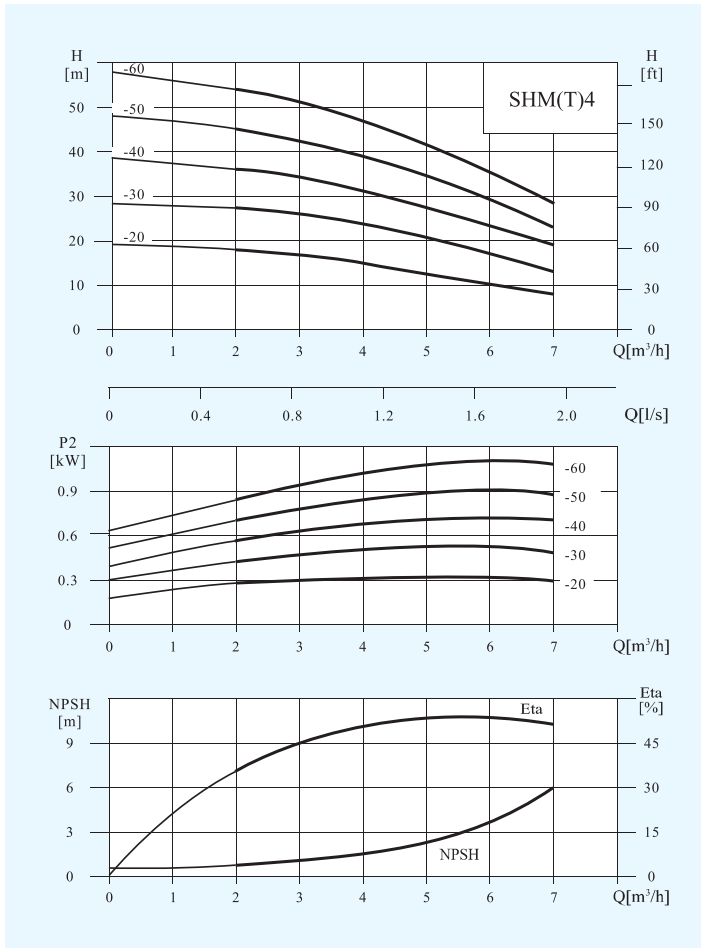

### SHM/SHMT

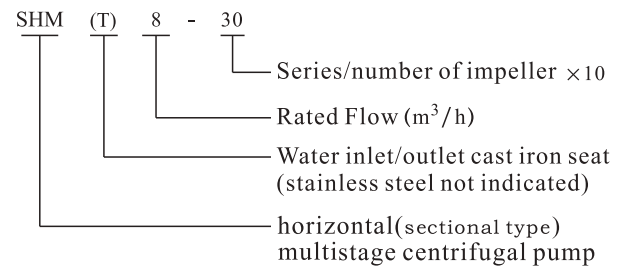

## Size and weight

Motor	Model	Size (mm)								Weight (kg)
		L1	L2	L3	E	H	N	D	K	
Three-phase/ single-phase	SHM4-20	359	105	102	182	230/245	110	170	/100	15
	SHM4-30	395	132	129	182	230/245	110	170	/100	17
	SHM4-40	465	159	156	190	240/260	118	170	/100	20
	SHM4-50	492	186	183	190	240/260	118	180	/100	25
	SHM4-60	519	213	210	190	240/260	118	180	/100	25

# Stainless Steel Horizontal Multistage Pump — 60Hz — SHM(T)4

## Structure chart:SHM

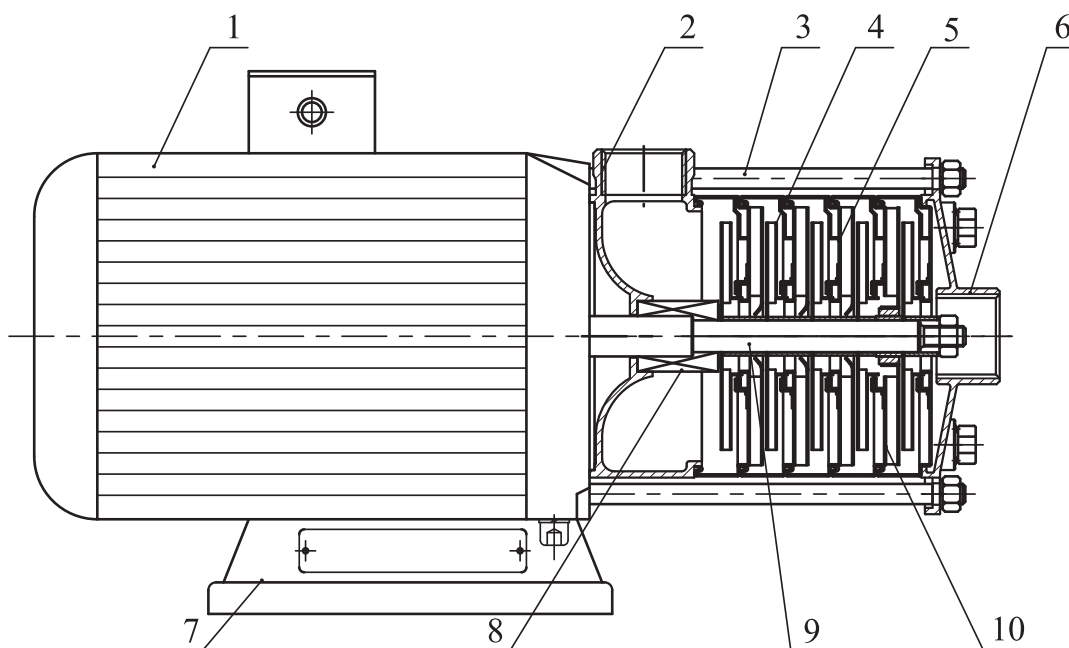

## Material SHM

No.	Name	Material	AISI / ASTM
1	Suction	Stainless steel	AISI304
2	Plug	Stainless steel	AISI304
3	Bearing	Tungsten carbide	
4	Impeller	Stainless steel	AISI304
5	Shaft	Stainless steel	AISI304
7	Discharge	Stainless steel	AISI304
8	Mechanical seal		
9	Motor end cover	Aluminum alloy	
10	Base plate	Cast iron	ASTM25B
11	Staybolt	Stainless steel	AISI304
12	Diffuser	Stainless steel	AISI304
13	Support diffuser	Stainless steel	AISI304
14	Impeller sleeve	Stainless steel	AISI304