

— Stainless Steel Horizontal Multistage Pump — 60Hz — SHM(T)20 —

Applications

- Air-conditioning system
- Cooling system
- Washing and cleaning system
- Water treatment
- Aquaculture
- Fertilizing / metering system
- Environmental application

Motor

- Fitted with a totally enclosed, fan-cooled
- Enclosure class: IP 55
- Insulation class: F
- Standard voltage: 1x220-230/240V (50Hz)
 - 3x200-220/346-380V
 - 3x220-240/380-415V
 - 3x220-255/380-440V



Operation conditions

- Liquid Temperature:
 - Normal temperature: -15°C~+70°C
 - Hot water: -15°C~+105°C
- Environment Temperature: Max. 40°C
- Altitude: Max. 1000m
- Operation pressure: Max. 10 bar

Material

- Inlet & outlet chamber: Cast iron/Stainless steel (304/316)
- Impeller: Stainless steel (304/316)
- Shell: Stainless steel (304/316)
- Shaft: Stainless steel (304/316)
- Mechanical seal: Graphite / SIC

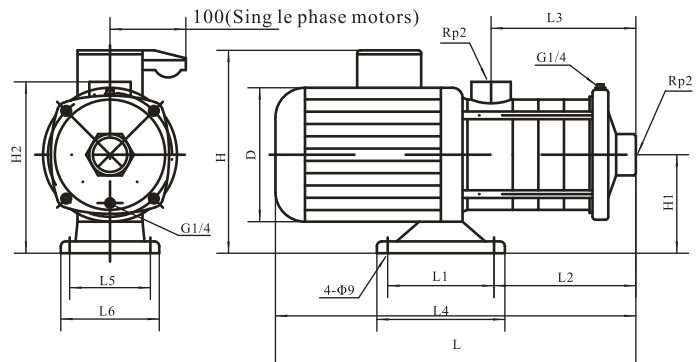

Performance table

Model	Driving motor		Q (m ³ /h)	12	14	16	18	20	22	24	26	28	30	32
	(kW)	(hp)		H (m)	18	17	16.5	16	15.5	14.5	13.5	12.5	11.5	10
SHM20-10	2.2	3		18	17	16.5	16	15.5	14.5	13.5	12.5	11.5	10	9
SHM20-20	4	5.5		37	36	35	34	32.5	31.5	30	29	27.5	24.5	22
SHM20-30	5.5	7.5		55	54.5	54	53	51.5	50.5	48	45.5	42	38.5	34
SHM20-40	7.5	10		74	73	71.5	70.5	69	67	64.5	61.5	57	51.5	46

Stainless Steel Horizontal Multistage Pump — 60Hz — SHM(T)20

Performance Curves

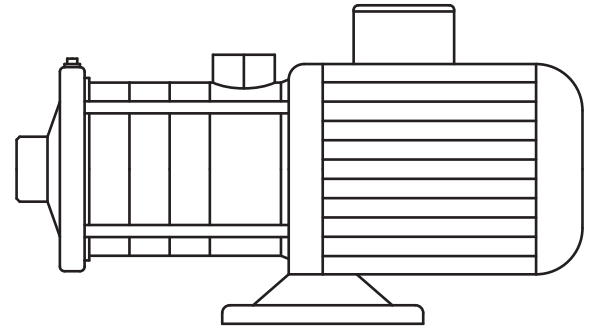
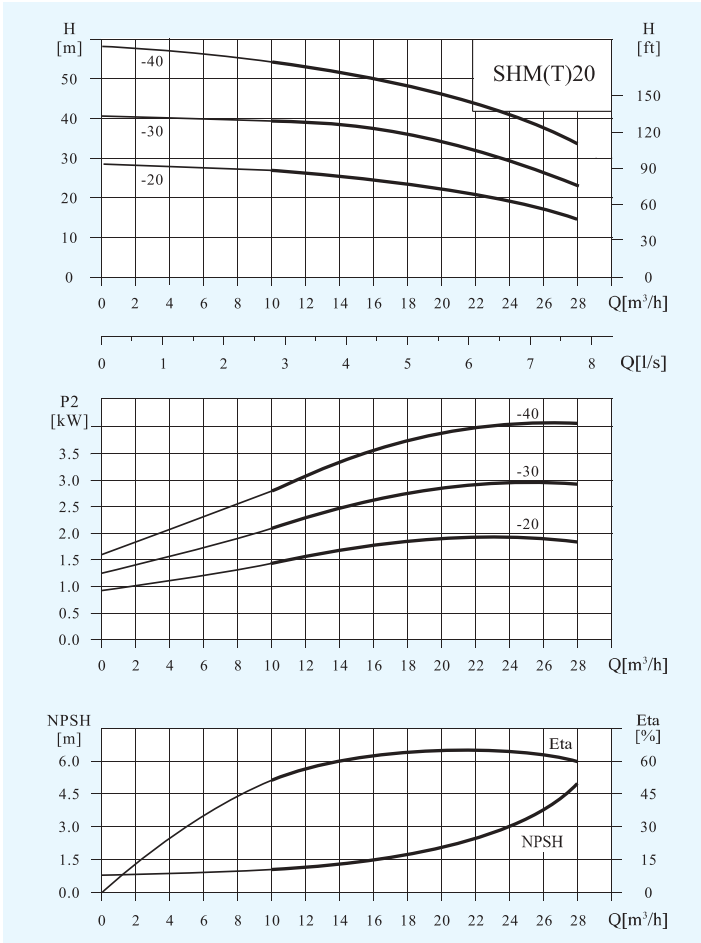

SHM/SHMT

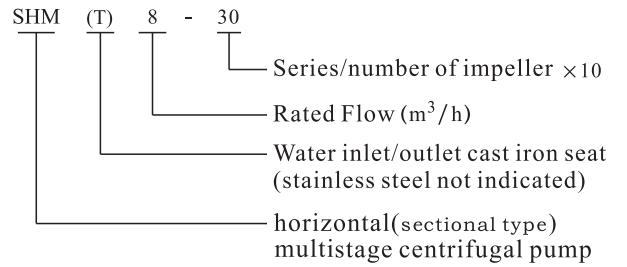

Size and weight

Motor	Model	Size (mm)													Weight (kg)
		L1	L2	L3	H	D	E	N	A	M	B	J	d	K	
Three-phase/ single-phase	SHM20-10	455	151	126	240/270	180	228	118	130	108	160	138	9	/100	26
	SHM20-20	531	249	126	270/	220	230	120	230	190	170	140	12		43
	SHM20-30	600	310	171	305/	255	242	132	260	216	190	140	12		56
	SHM20-40	645	355	216	305/	255	242	132	260	216	190	140	12		63

Stainless Steel Horizontal Multistage Pump — 60Hz — SHM(T)20

Structure chart:SHM

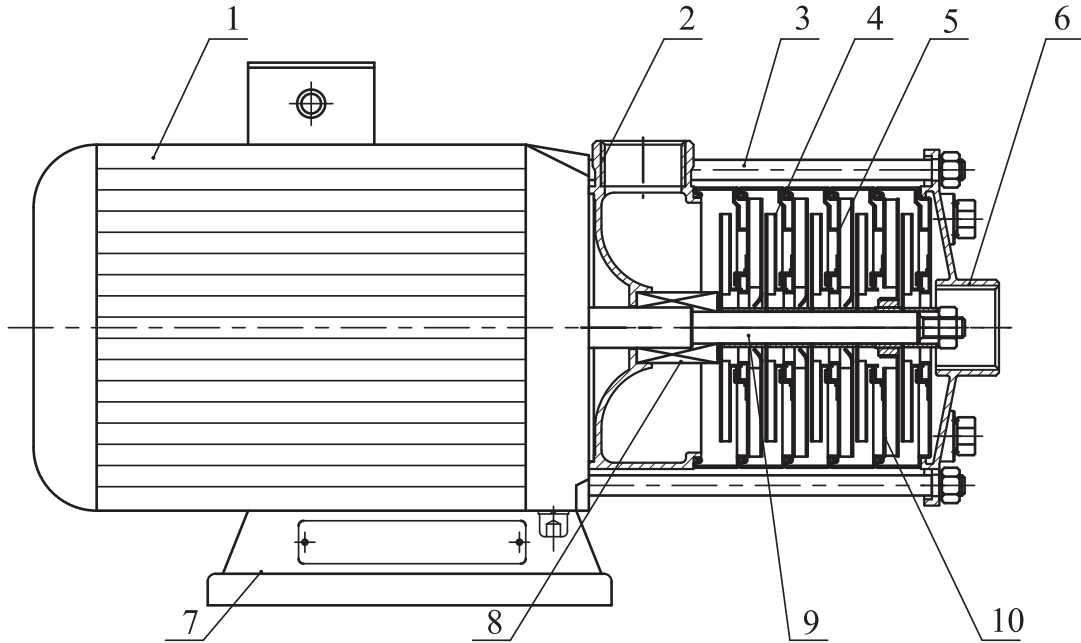

Material SHM

No.	Name	Material	AISI / ASTM
1	Suction	Stainless steel	AISI304
2	Plug	Stainless steel	AISI304
3	Bearing	Tungsten carbide	
4	Impeller	Stainless steel	AISI304
5	Shaft	Stainless steel	AISI304
7	Discharge	Stainless steel	AISI304
8	Mechanical seal		
9	Motor end cover	Aluminum alloy	
10	Base plate	Cast iron	ASTM25B
11	Staybolt	Stainless steel	AISI304
12	Diffuser	Stainless steel	AISI304
13	Support diffuser	Stainless steel	AISI304
14	Impeller sleeve	Stainless steel	AISI304