

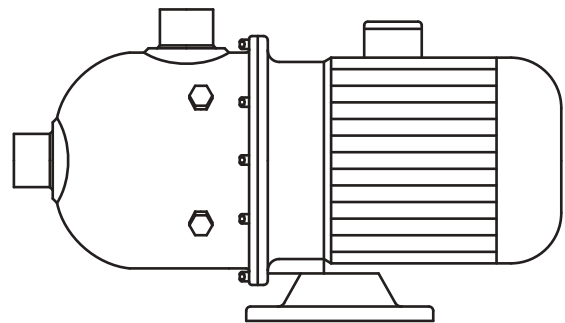

# Stainless Steel Horizontal Multistage Pump — CM4

## Performance Curves

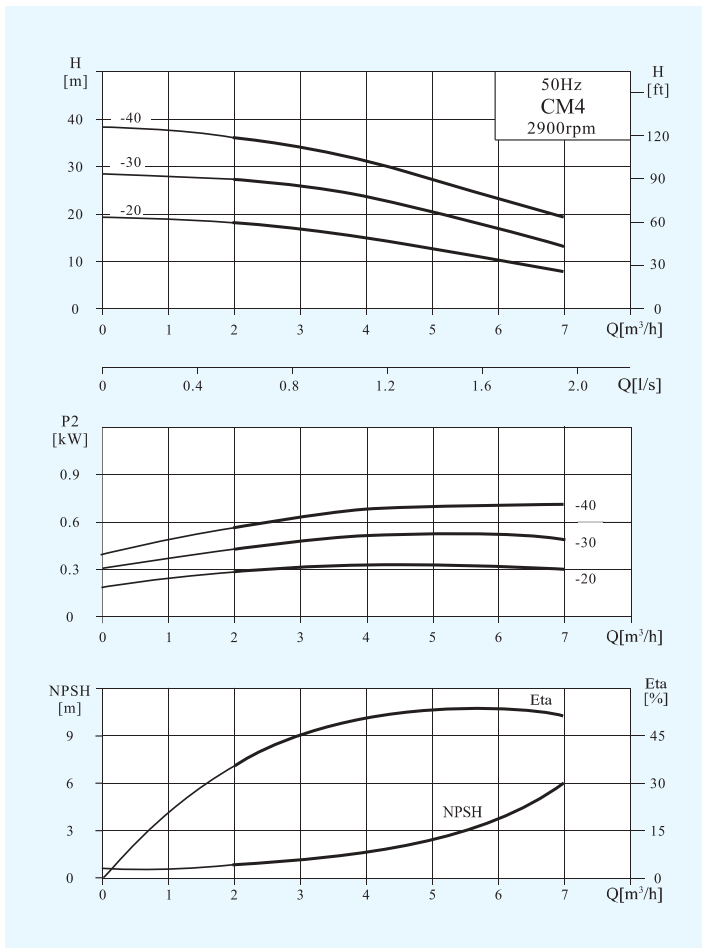

## CM

CM    4    -    40  
 ——— Series/number of impeller × 10  
 ——— Rated Flow (m³/h)  
 ——— horizontal multistage centrifugal pump  
 (Wet parts component made of SS 304 -316L)

## Dimension & Weight

Motor	Model	Specification (mm)				Net Weight (kg)
		L	D	H	L1	
Three phase /Single phase	CM4-20	400	145	215/230	/96	12
	CM4-30	400	145	215/230	/96	13
	CM4-40	445	170	225/245	/100	15

# Stainless Steel Horizontal Multistage Pump CM4

## Structure chart:CM

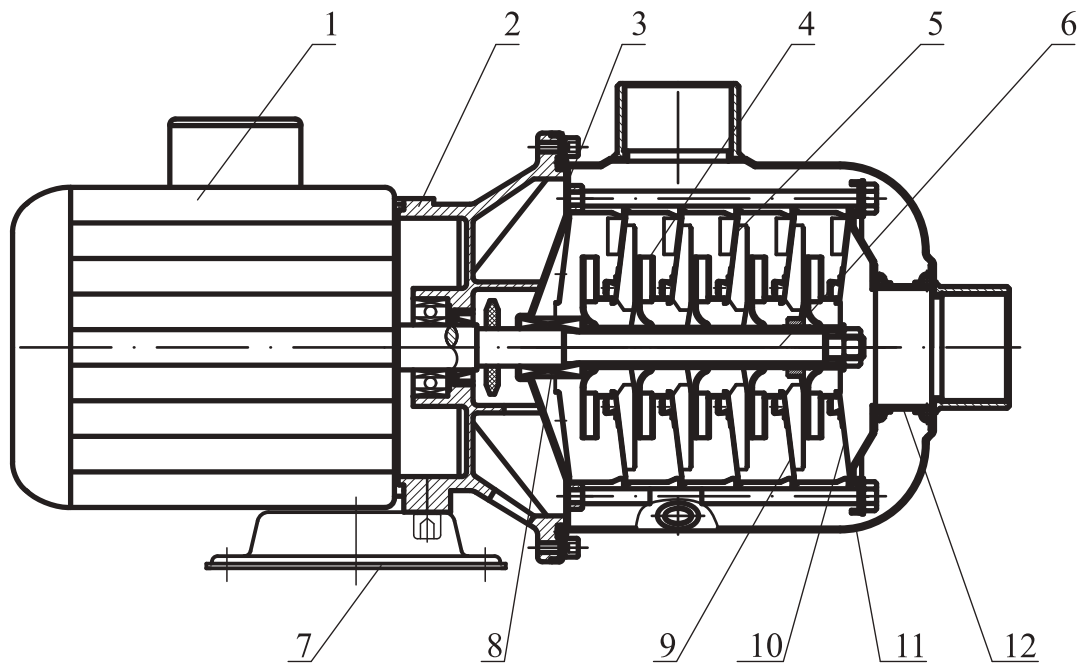

## Material:CM

No	Description	Material	AISI/ASTM	No	Description	Material	AISI/ASTM
1	Motor	Assembling unit		7	Seat	Steel	AISI1015
2	Motor front housing	Aluminium alloy		8	Mechanical seal	Assembling unit	
3	Seal seat	Stainless steel	AISI304	9	Support diffuser	Stainless steel	AISI304
4	Impeller	Stainless steel	AISI304	10	Inlet diffuser	Stainless steel	AISI304
5	Diffuser	Stainless steel	AISI304	11	Casing	Stainless steel	AISI304
6	Shaft	Stainless steel	AISI304	12	Inlet pipeline	Stainless steel	AISI304