

Stainless Steel Horizontal Multistage Pump — 60Hz — CM16

Structure chart:CM

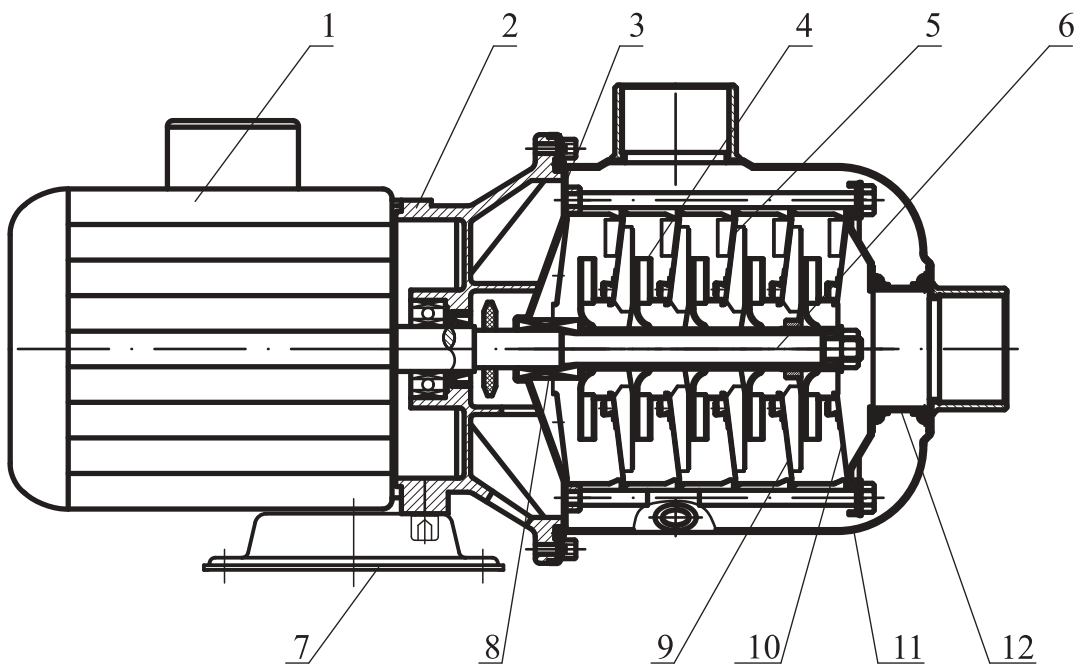

Material CM

No.	Name	Material	AISI / ASTM
1	Inlet and outlet chamber	Stainless steel	AISI304
2	Connection pipe	Stainless steel	AISI304
3	Clamp plate	Stainless steel	AISI304
4	Impeller	Stainless steel	AISI304
5	Shaft	Stainless steel	AISI304
6	Plug	Stainless steel	AISI304
7	Discharge diffuser	Stainless steel	AISI304
8	Mechanical seal		
9	Motor end cover	Aluminum alloy	
10	Base plate	Cast iron	ASTM25B
11	Spannband	Stainless steel	AISI304
12	Diffuser	Stainless steel	AISI304
13	Support diffuser	Stainless steel	AISI304
14	Inducerr	Stainless steel	AISI304